

Recent Developments in Electric Power Transmission Technology

Dr. Kalyan Sen

April 15, 2003

Issues Facing Power Industry Today

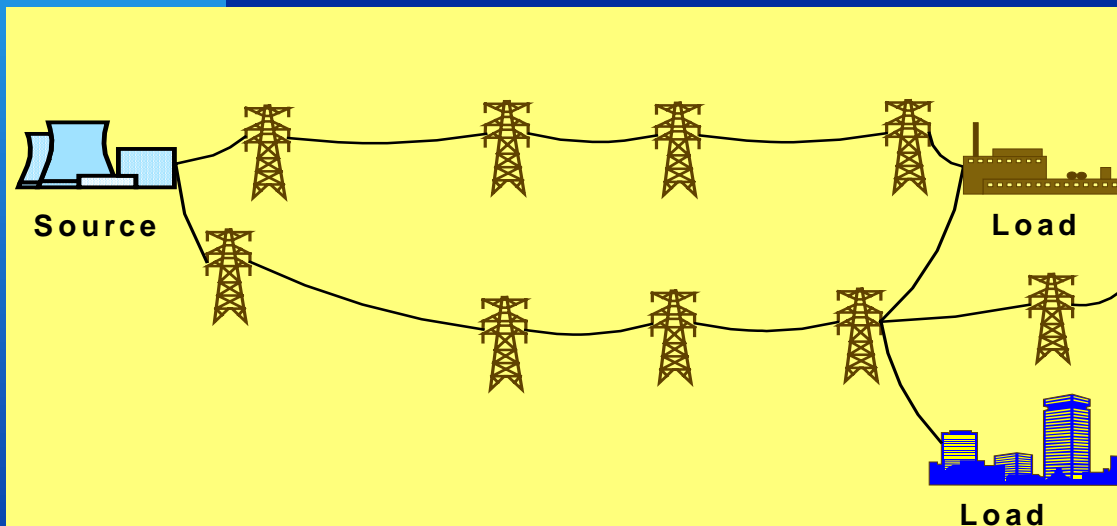

- Demand for electrical energy is increasing.
- “Free Flow” makes particular transmission lines overloaded.
- Construction of new transmission lines has become increasingly difficult and expensive.
- Energy needs to be transported from the generating point to the end-user along the most desirable path.

Issues Facing Power Industry Today

- Voltage level may need to be restored at a point along the line.

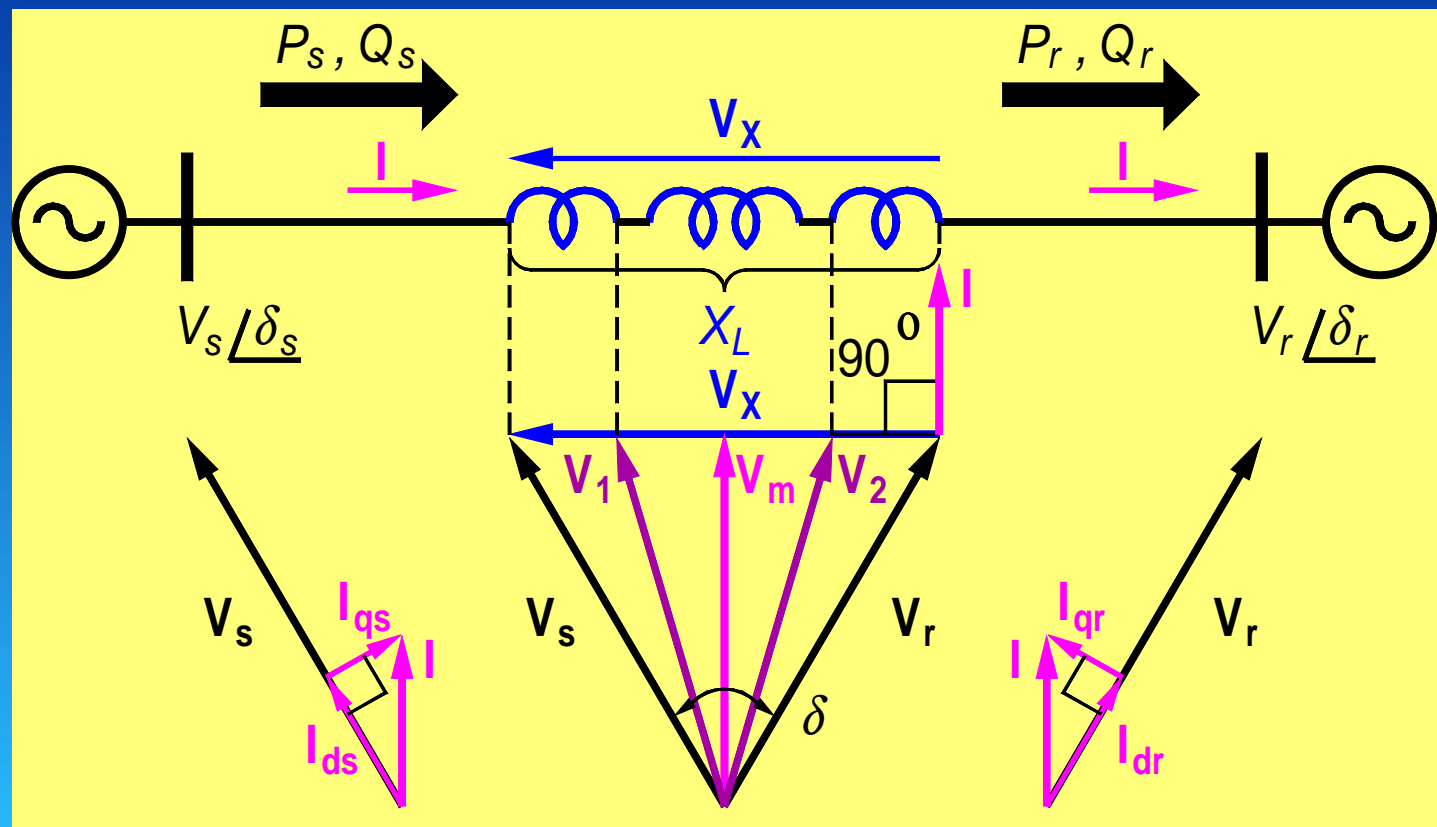

Principles of Power Flow in a Transmission Line

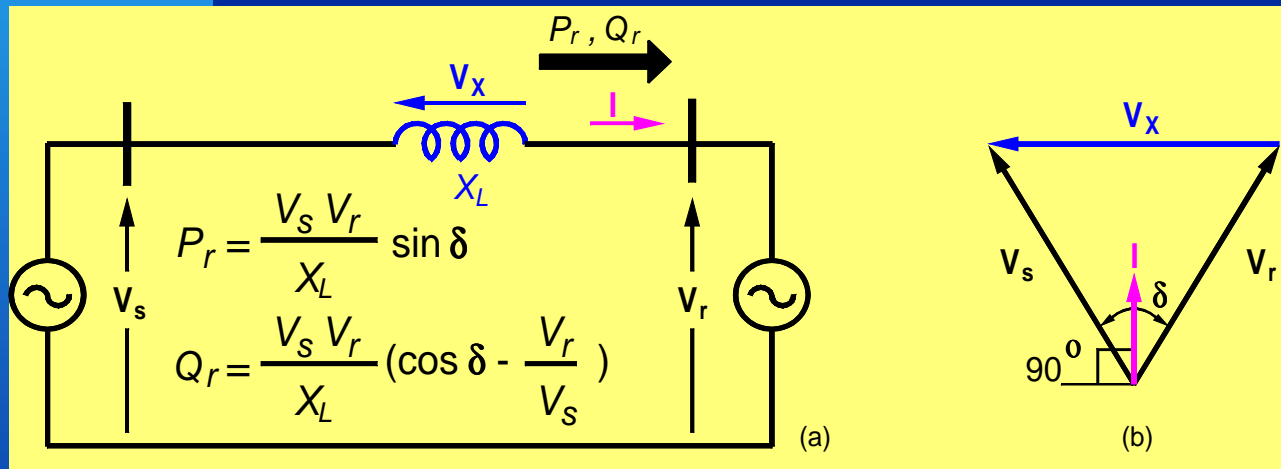

- Power flow in a transmission line depends on
 - impedance
 - voltage
 - phase angle.
- Leading voltage sends active power to the lagging voltage.

Available Solutions

■ Traditional Technology

- Voltage-Regulating Transformer
- Shunt Inductor/Capacitor
- Series Inductor/Capacitor
- Phase Angle Regulator

■ Voltage-Sourced Converter Based Technology

- STATic synchronous COMPensator (STATCOM)
- Static Synchronous Series Compensator (SSSC)
- Unified Power Flow Controller (UPFC)

Voltage-Regulating Transformer

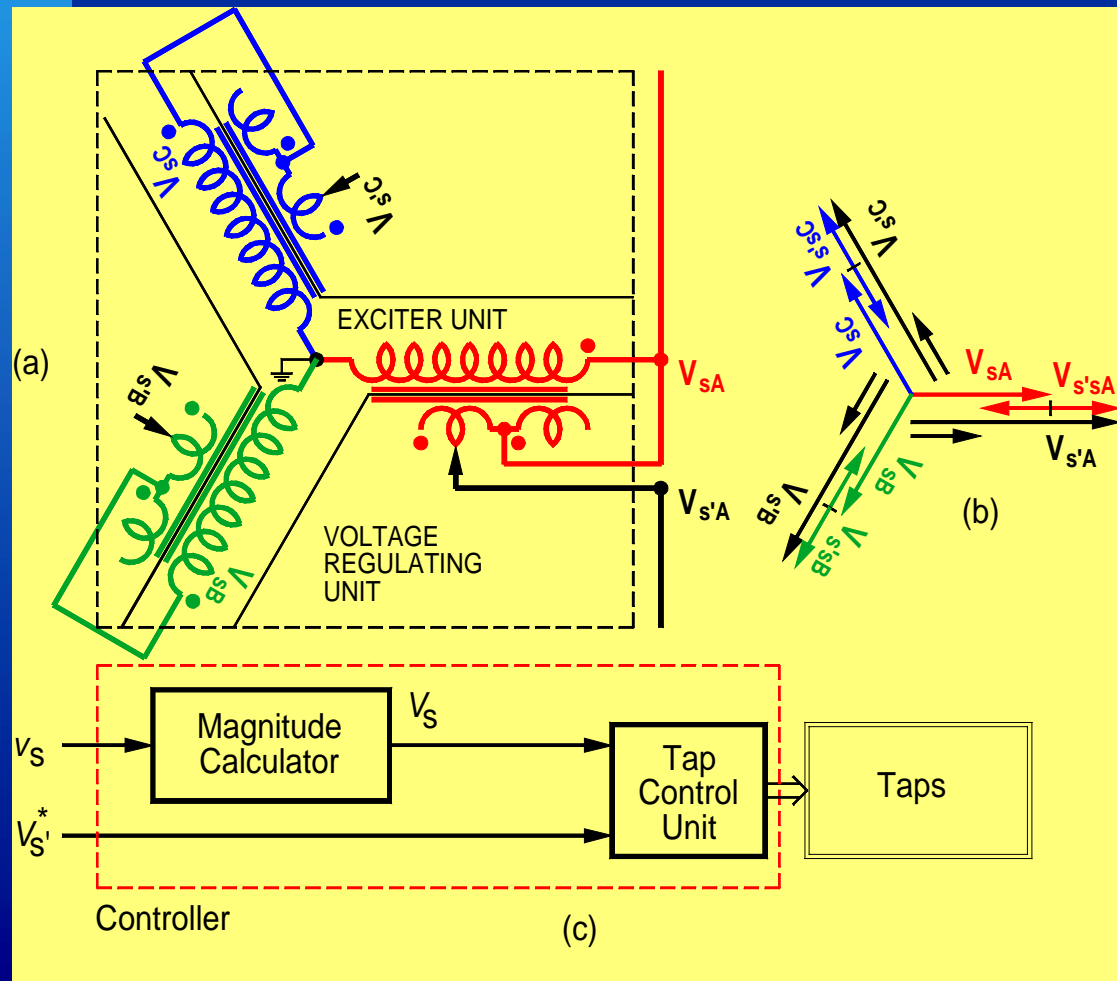

- Regulates the line voltage in small steps by adding or subtracting a compensating voltage in series with the transmission line.

Voltage-Regulating Transformer

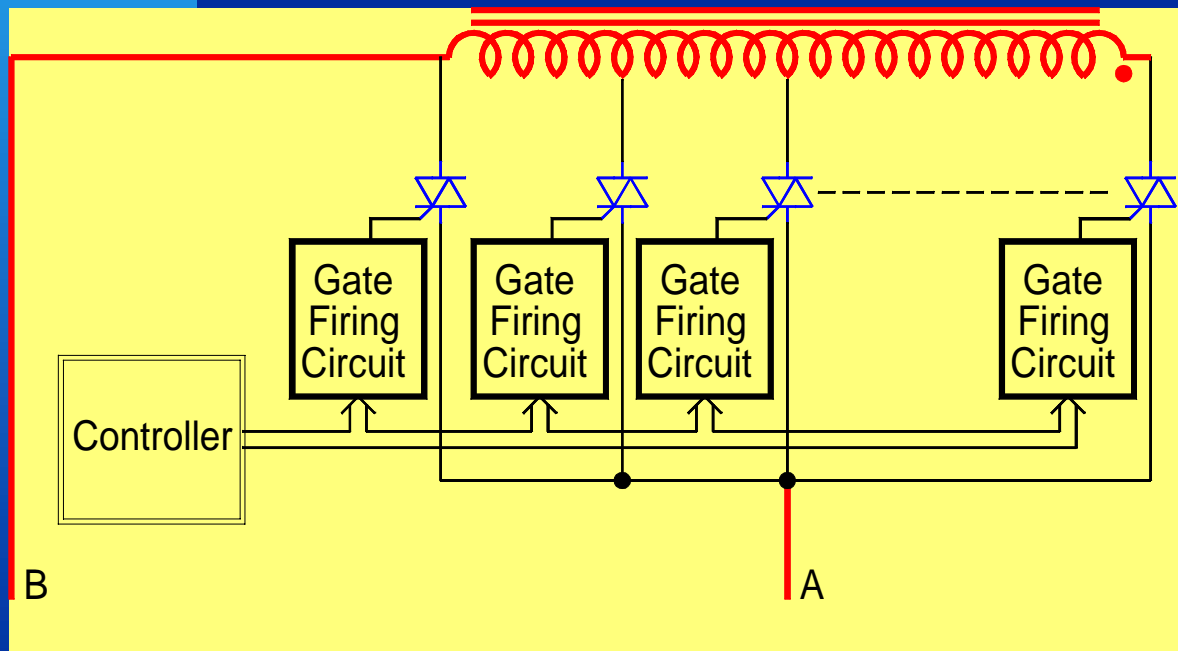

■ Produces a variable voltage.

Thyristor-Controlled Static Var Compensator

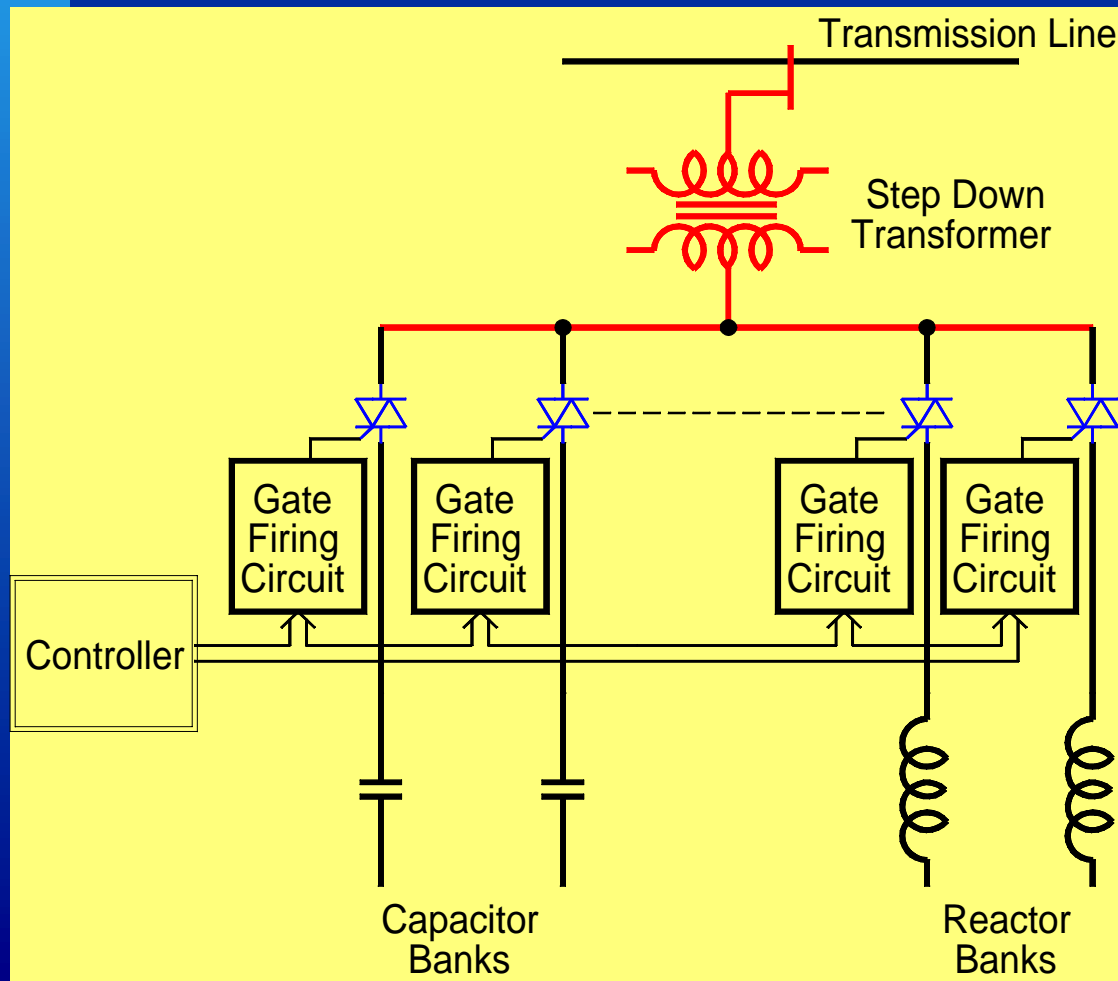

- Regulates the line voltage by connecting an inductor or a capacitor in parallel with the transmission line.

Voltage and Current of a Thyristor-Controlled Reactor

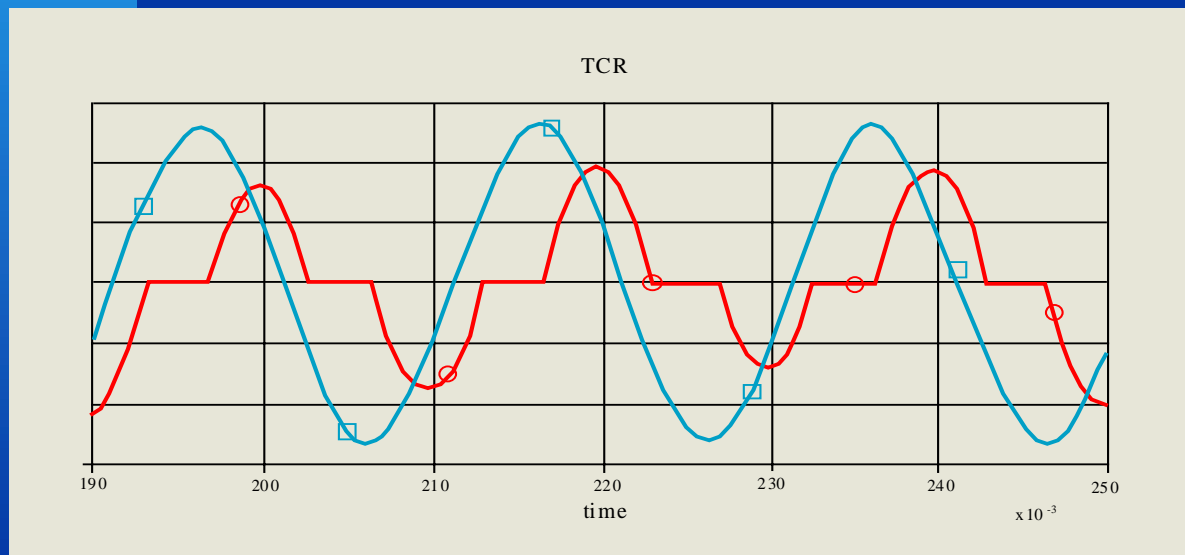

TCR current
Bus voltage

STATIC synchronous COMPensator-STATCOM

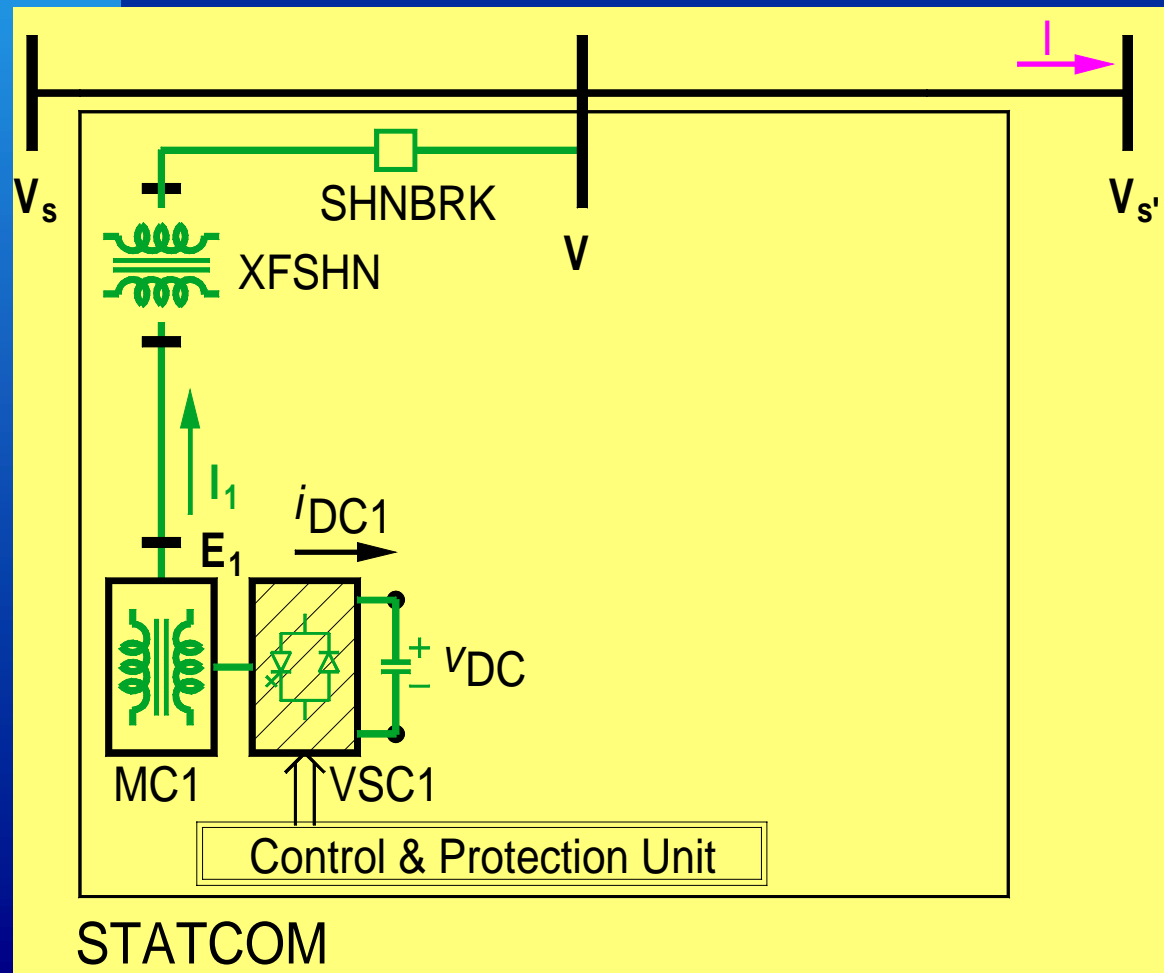

- Regulates the line voltage by injecting a shunt reactive current into the transmission line.

A STATCOM Operating in Inductive and Capacitive Modes

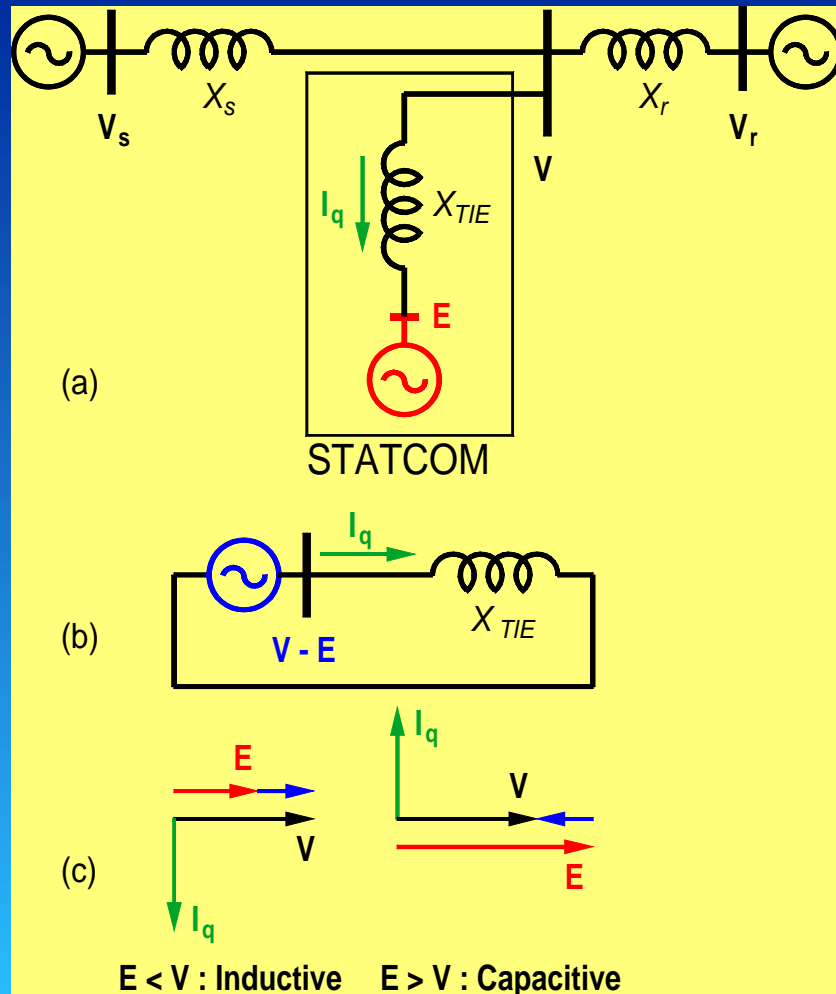

- Inductive operation means $E < V$.
- Capacitive operation means $E > V$.

Thyristor-Switched Series Capacitor (TSSC)

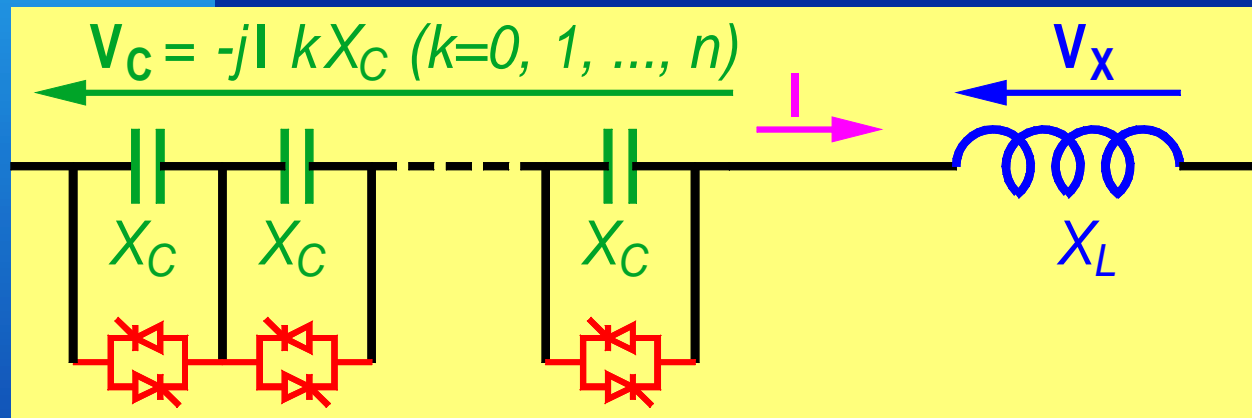

- Regulates the transmission line's effective reactance by connecting a capacitor, parallel with a bypass switch, in series with the transmission line.

Static Synchronous Series Compensator-SSSC

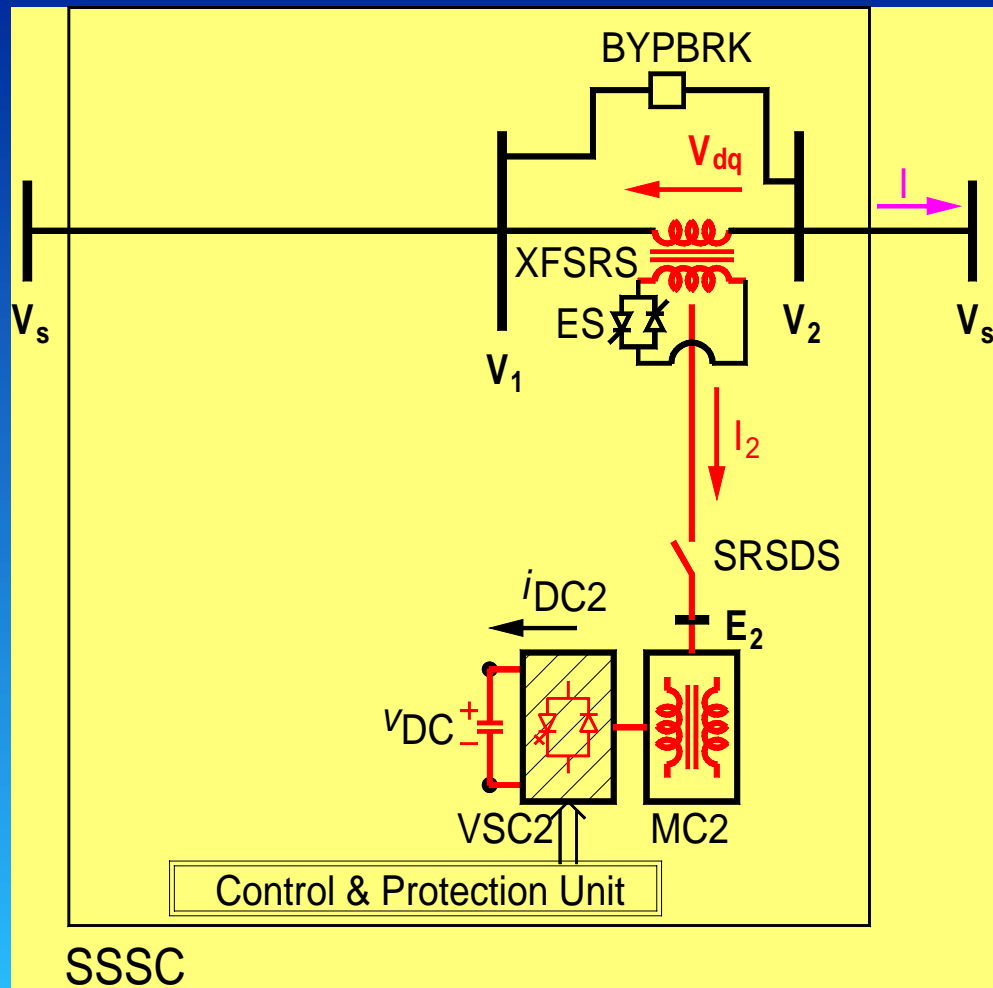

- Regulates the transmission line's effective reactance by connecting a compensating voltage in series with the line and in quadrature with the prevailing line current.

An SSSC Operating in Inductive and Capacitive Modes

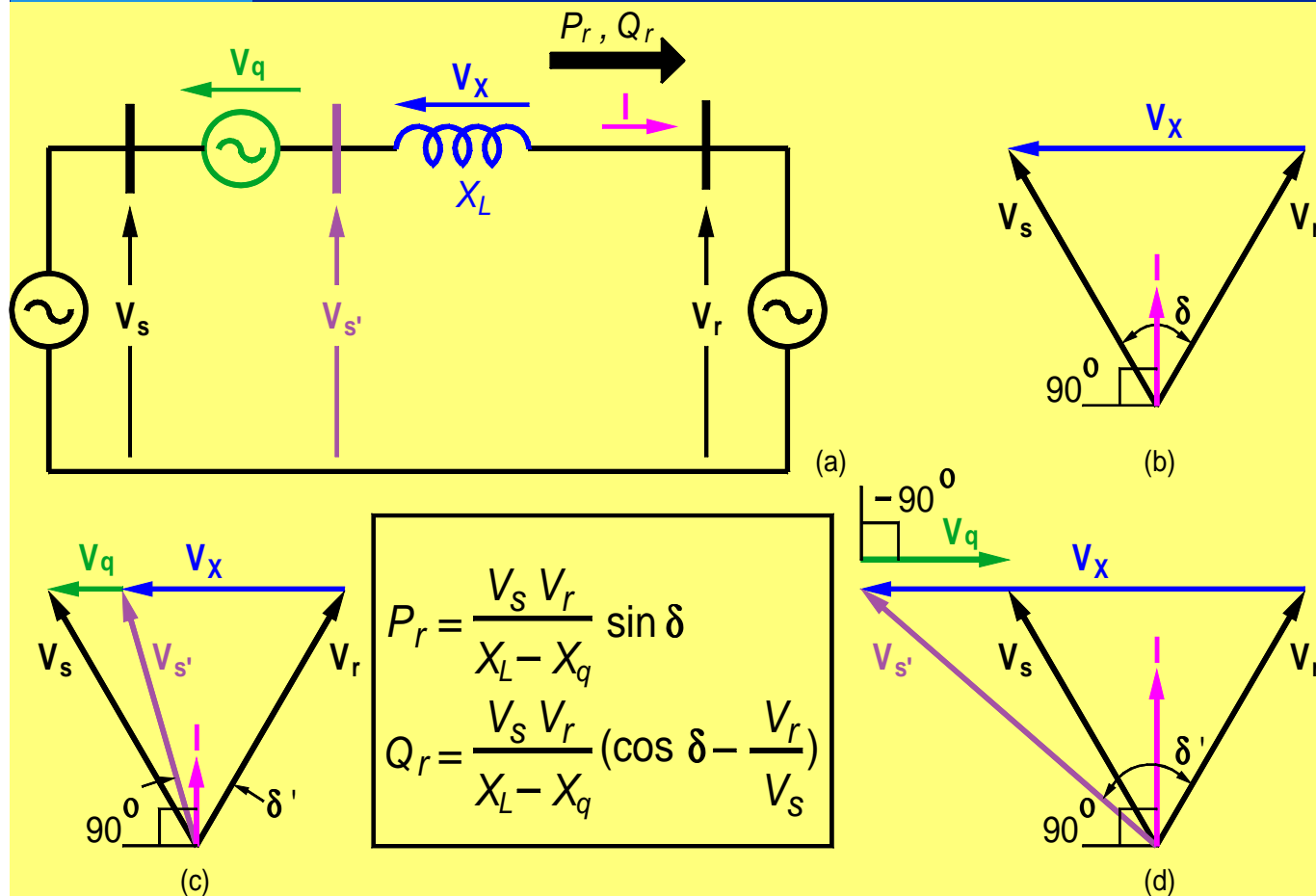

■ A series-injected voltage while

- leading the prevailing line current, provides an inductive compensation
- lagging the prevailing line current, provides a capacitive compensation

A Phase Angle Regulator

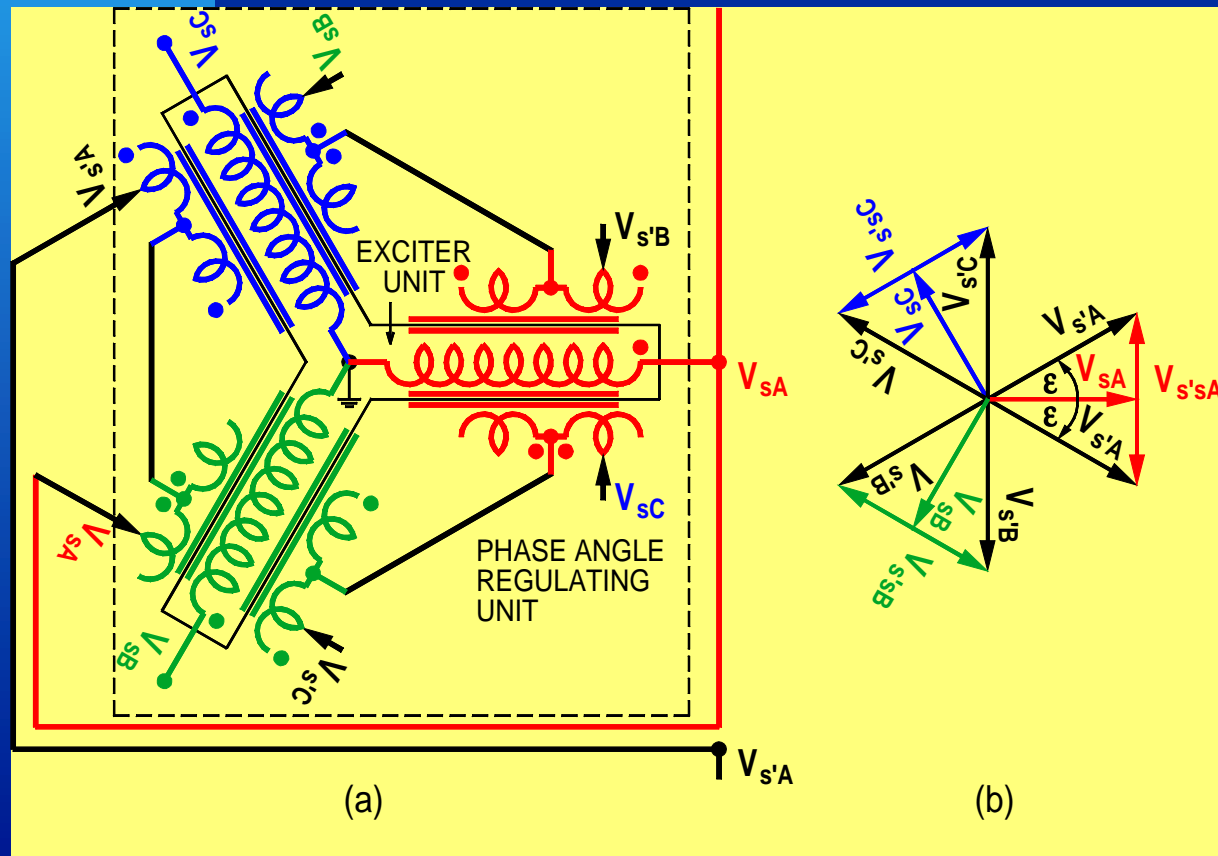

- Regulates the phase angle of the line voltage by a series-connected compensating voltage that is in quadrature with respect to the line voltage.

The Effect of a Series-Injected Voltage on Power Flow in a Transmission Line

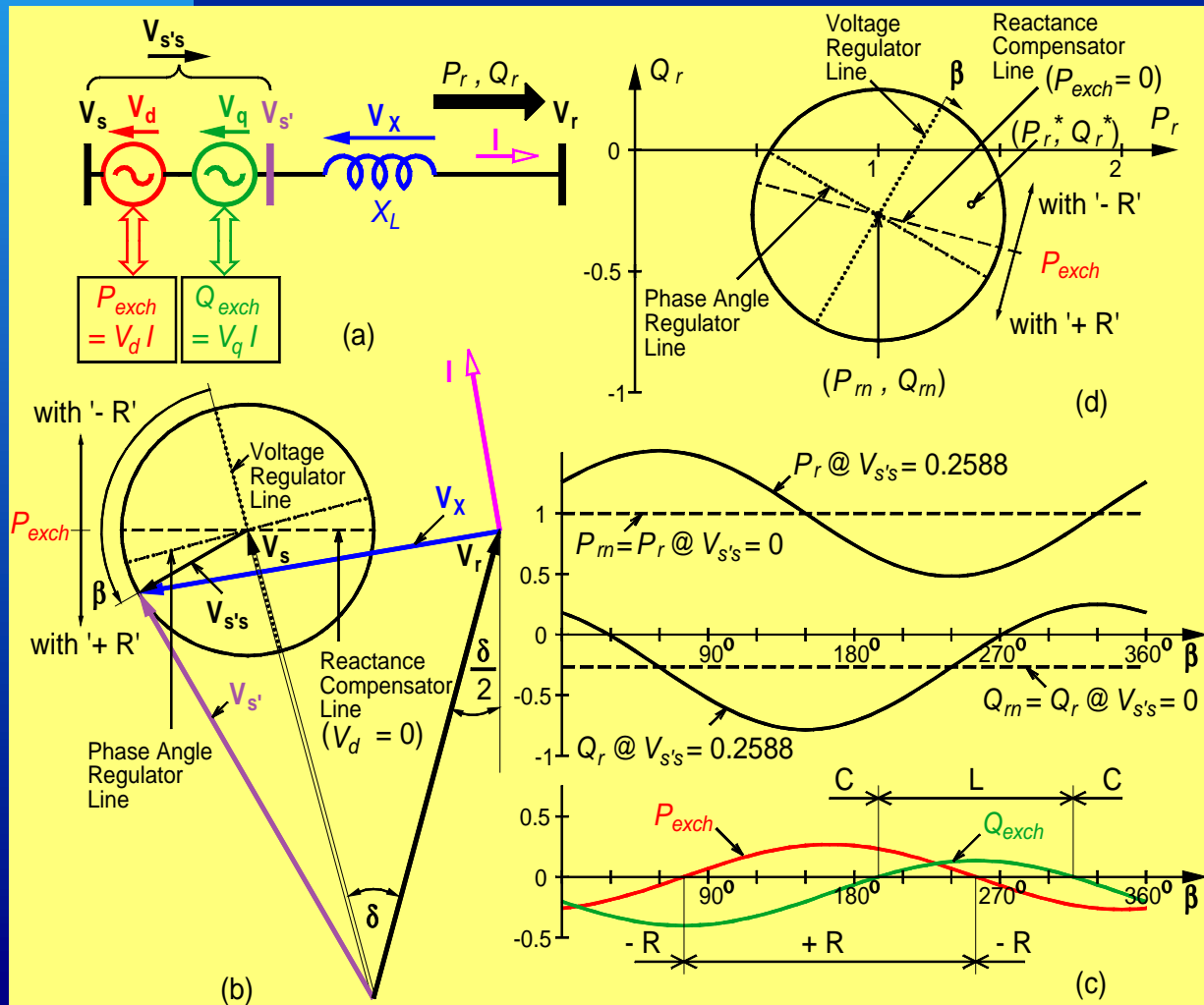

- Active and reactive power flow in the line is regulated independently.
- Exchanged power by the series unit is active and reactive.

Characteristics of Power Flow Controllers

- Traditional power flow controllers
 - each controls only one of the three parameters (voltage, reactance or angle).
- Single Voltage-Sourced Converter-based power flow controllers
 - each controls one of the transmission line parameters.
 - can have fast dynamic response.
- Dual Voltage-Sourced Converter-based power flow controllers
 - can exchange real power with the line and generate or absorb reactive power.

Unified Power Flow Controller-UPFC

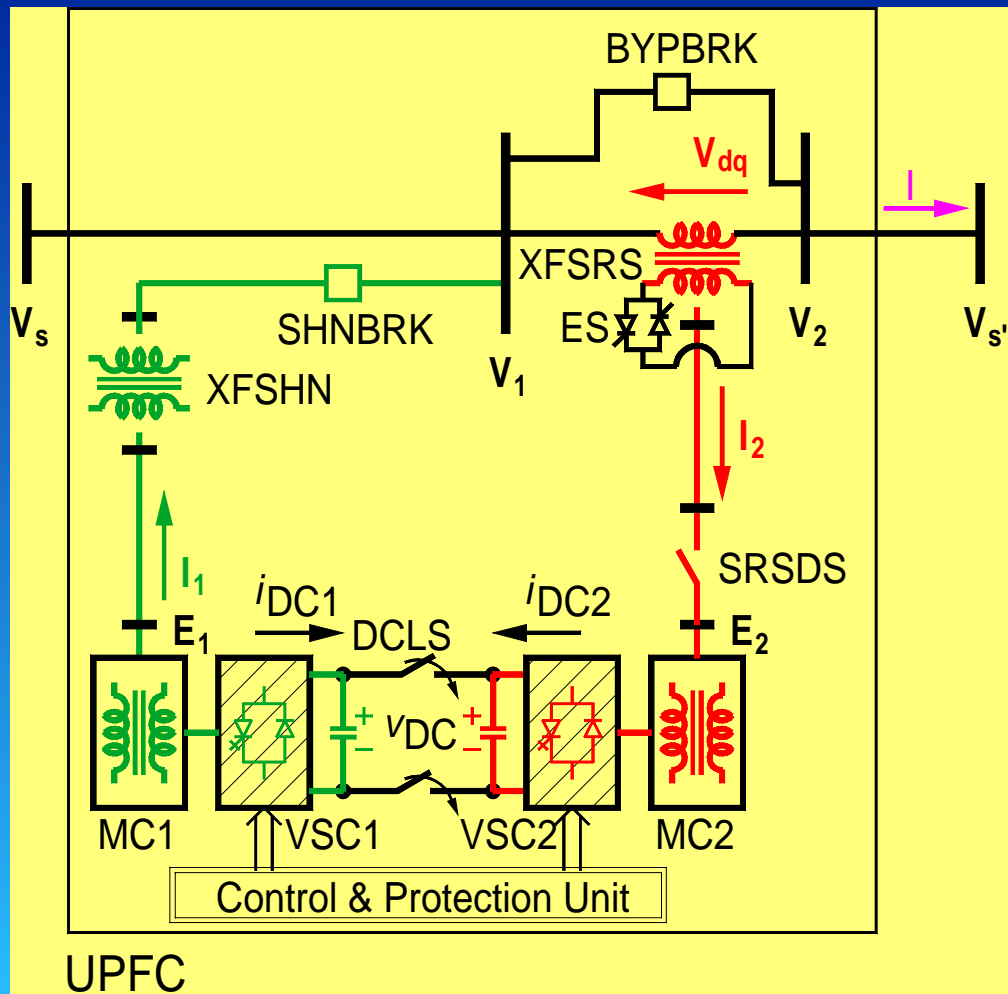

- Regulates the active and the reactive power flow in the line independently.
- Regulates the line voltage by injecting a shunt reactive current into the transmission line.

AEP UPFC Test Results

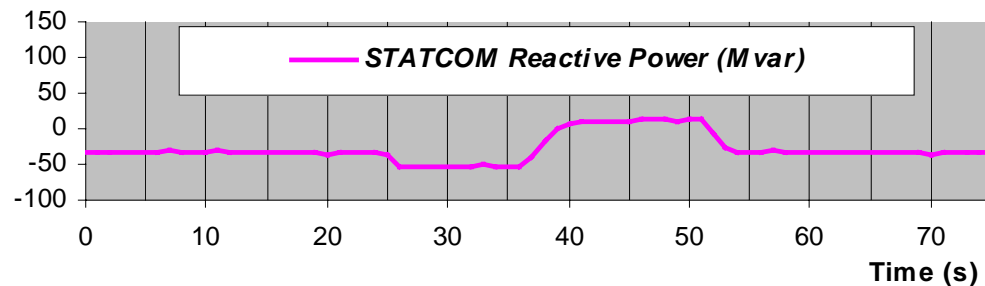
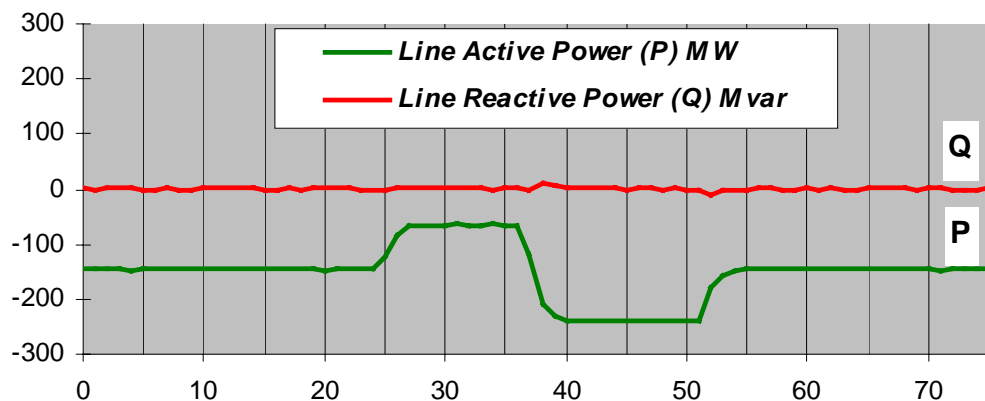
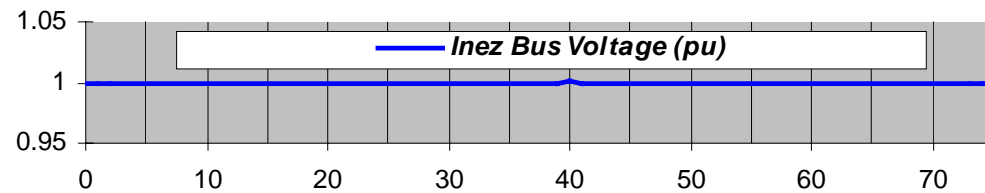

■ Holding unity power factor while changing line active power.

■ Sub-cycle performance of a UPFC is not required in a utility application.

What Are We Looking For in a Utility Application?

- A power flow controller that is
 - reliable
 - independent regulator of active (P) and reactive (Q) power flow
 - fast enough for a utility application
 - inexpensive

'Sen' Transformer Concept

- Combines power flow control parameters, using a single-core three-phase transformer with load tap changers,
 - voltage
 - phase angle
 - reactance
- Regulates active and reactive power flow selectively,
- Regulates line voltage.

'Sen' Transformer

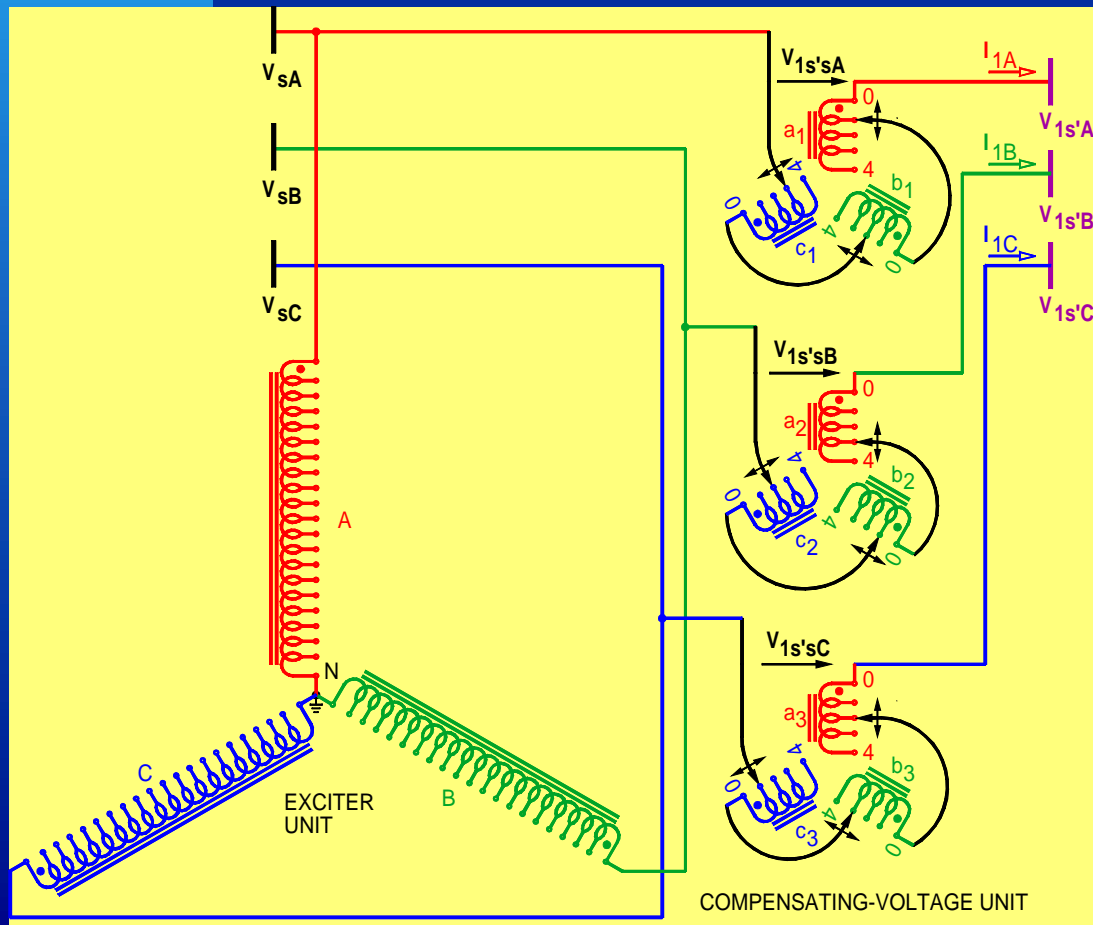

- Regulates line voltage like an autotransformer.
- Controls active and reactive power flow in the line by a series-connected compensating voltage that is at any angle with respect to the line voltage.

'Sen' Transformer Operation

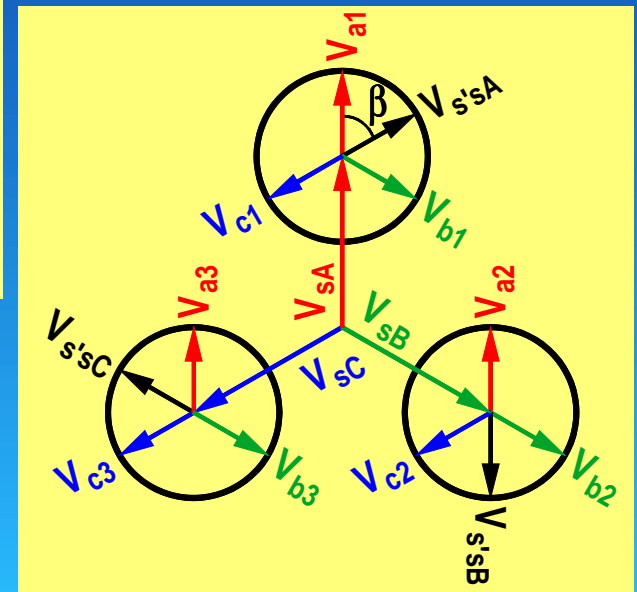
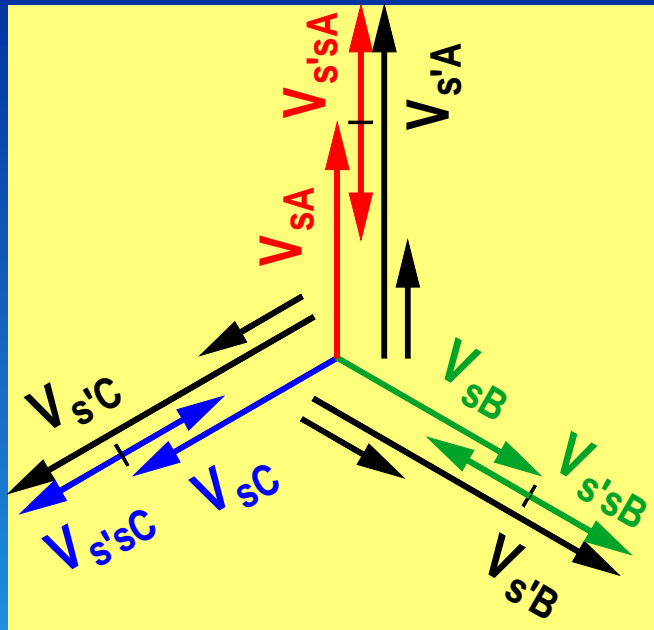
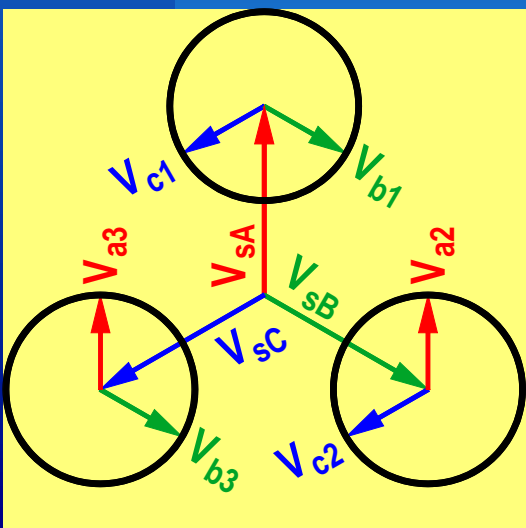
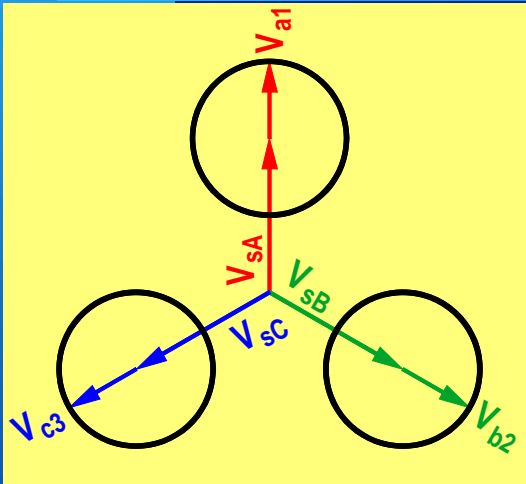

Practical Compensator's Operating Range

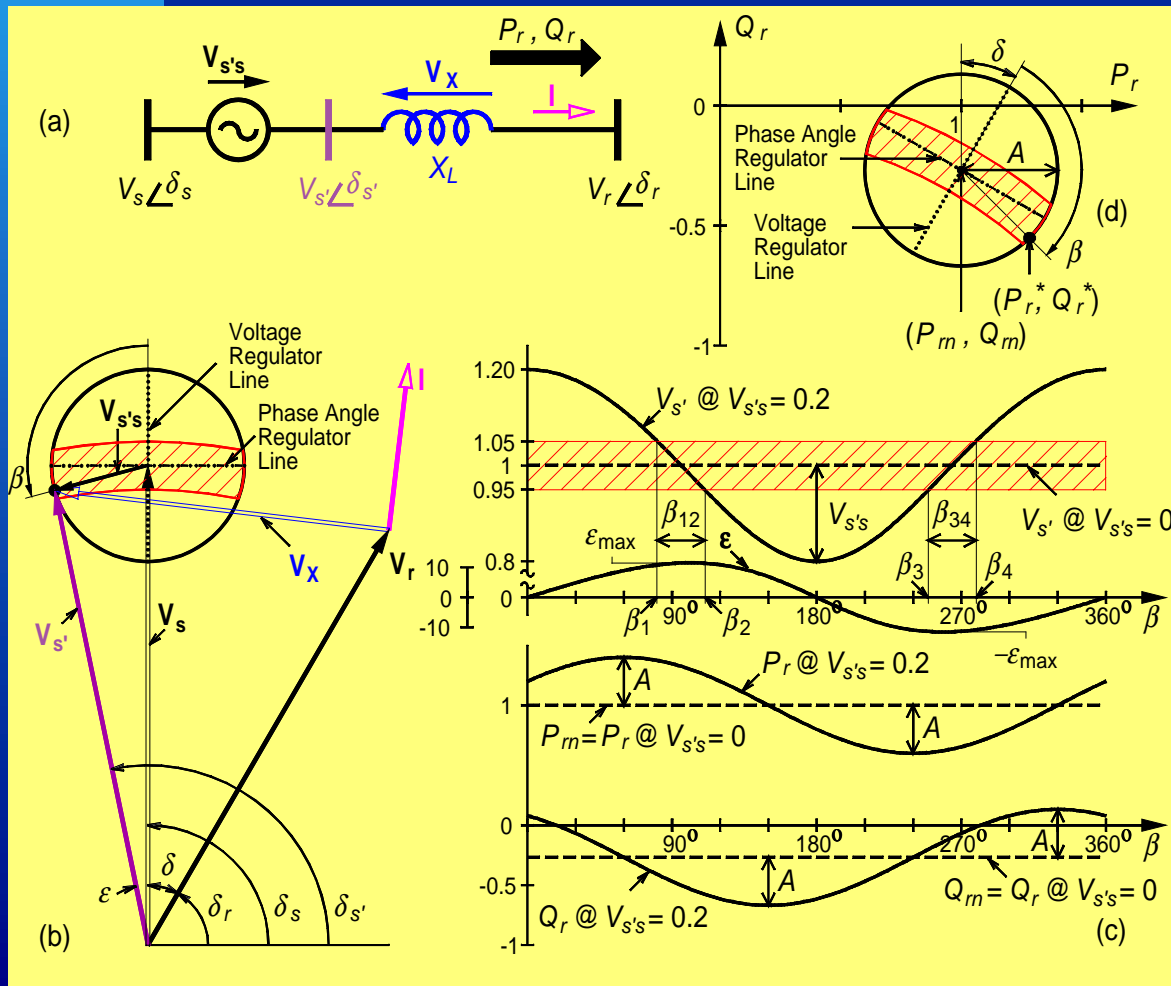

- Line voltage is bounded by $\pm 5\%$ over nominal voltage.
- Full range of voltage injection is not permitted.
- Full capability of a UPFC is not utilized.
- ST can be modified to fit customers' needs.

Limited Angle Operation of a 'Sen' Transformer

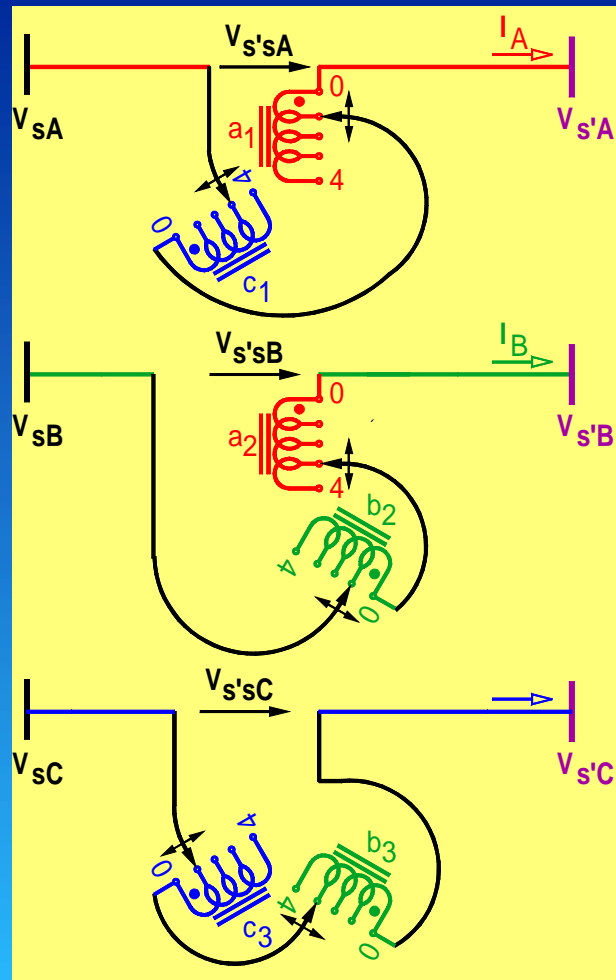

- Injects voltage from 0° to 120° .

Limited Angle Operation of a 'Sen' Transformer

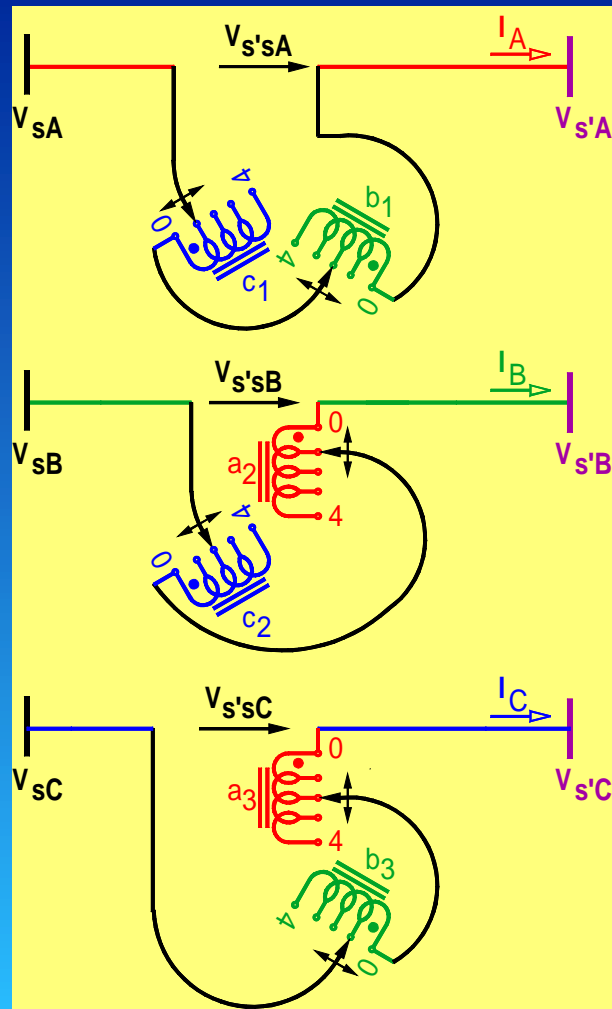

- Injects voltage from 120° to 240° .

Limited Angle Operation of a 'Sen' Transformer

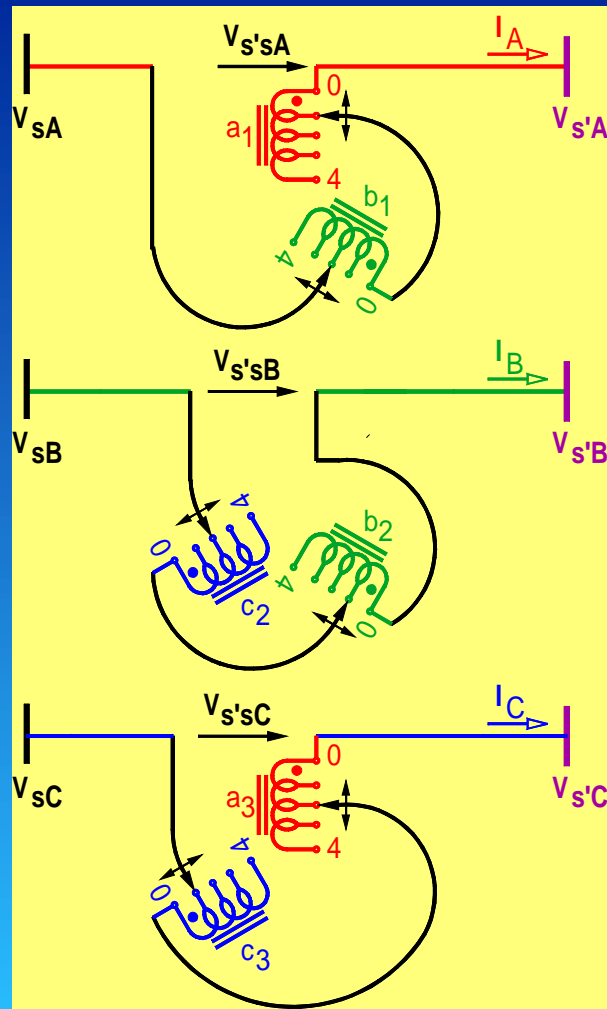

- Injects voltage from 240° to 360° .

A Power Flow Controller in a 2-Bus Network

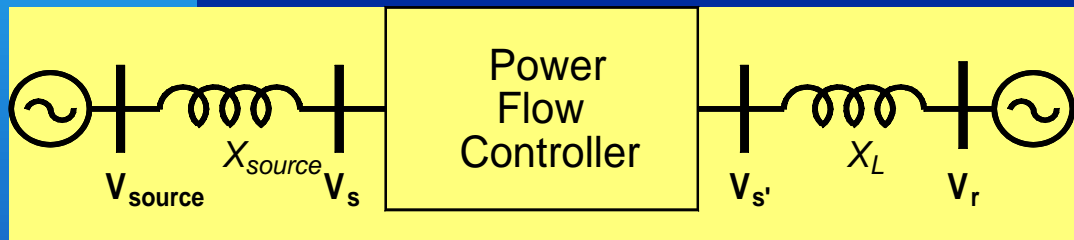

- Controls the active and the reactive power flow in the line by a series-injected voltage that is at any angle with respect to the line voltage.

Simulation of ST and UPFC ($V_{s's} = 0.15$ pu)

- The exchanged power by the series unit of an ST and a UPFC are identical.

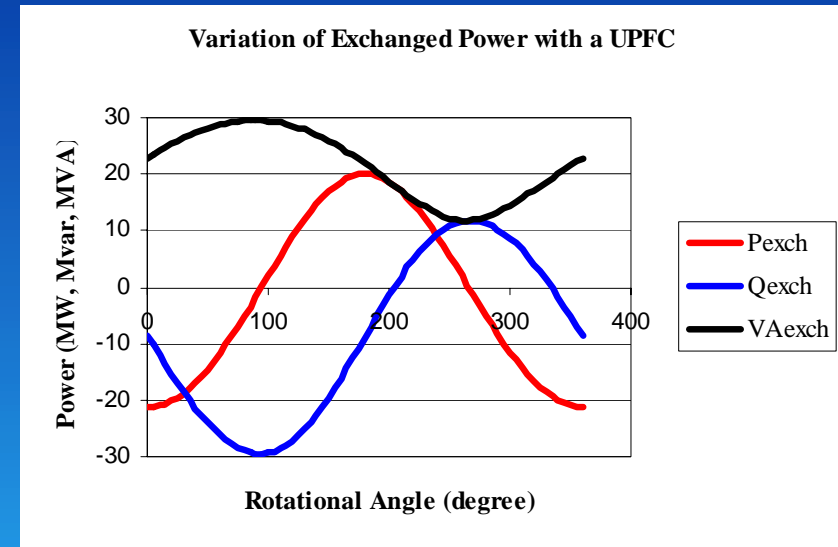
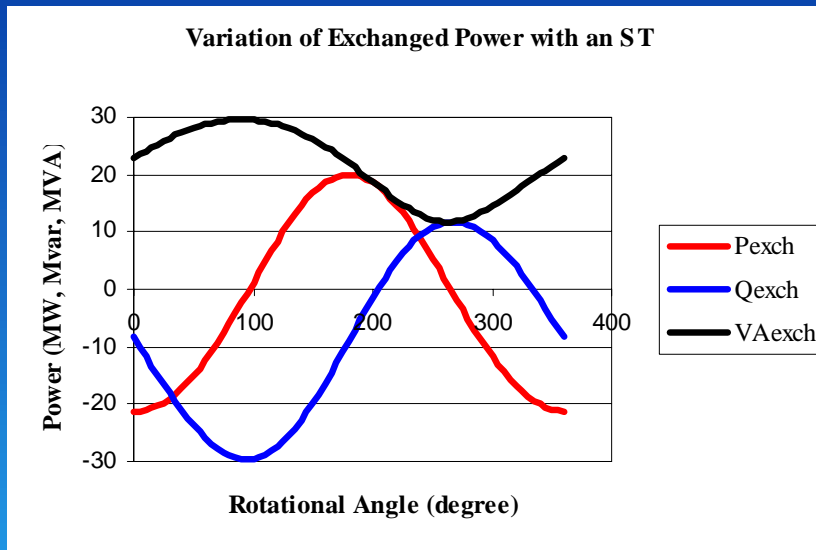

Simulation of ST and UPFC ($V_{s's} = 0.15$ pu)

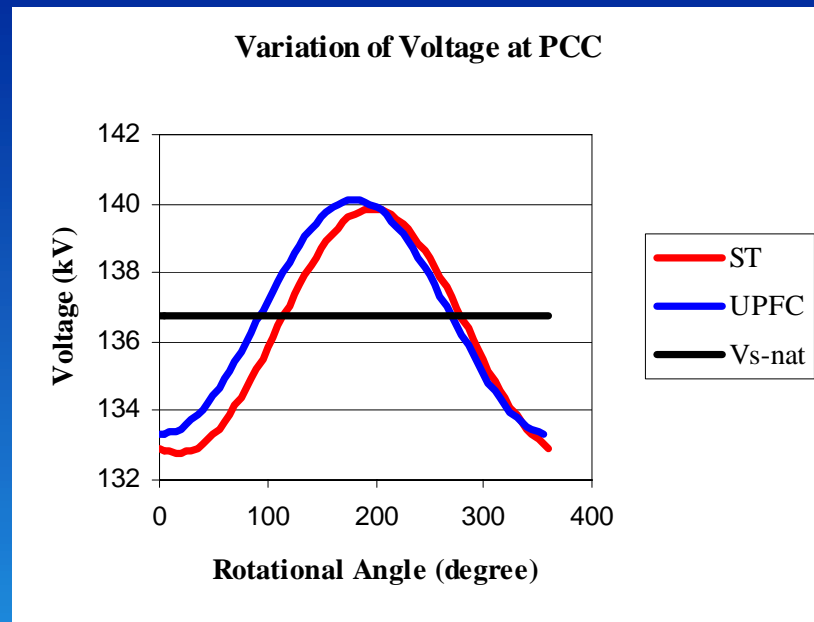

- From 205° to 335°, an ST maintains a higher line voltage than a UPFC.
- From 0° to 205° and 205° to 335°, a UPFC maintains a higher line voltage than an ST.

Simulation of ST and UPFC ($V_{s's} = 0.15$ pu)

- The variation of power flow, at the receiving-end of the transmission line, by an ST and a UPFC are identical.

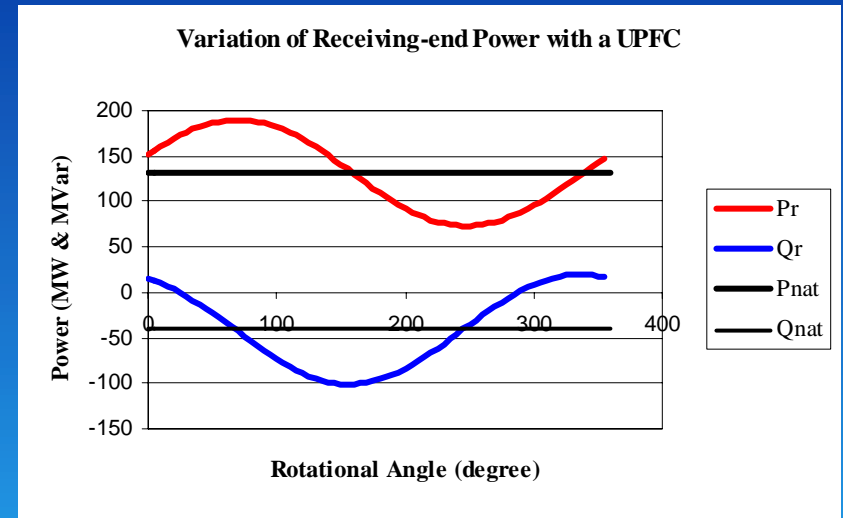
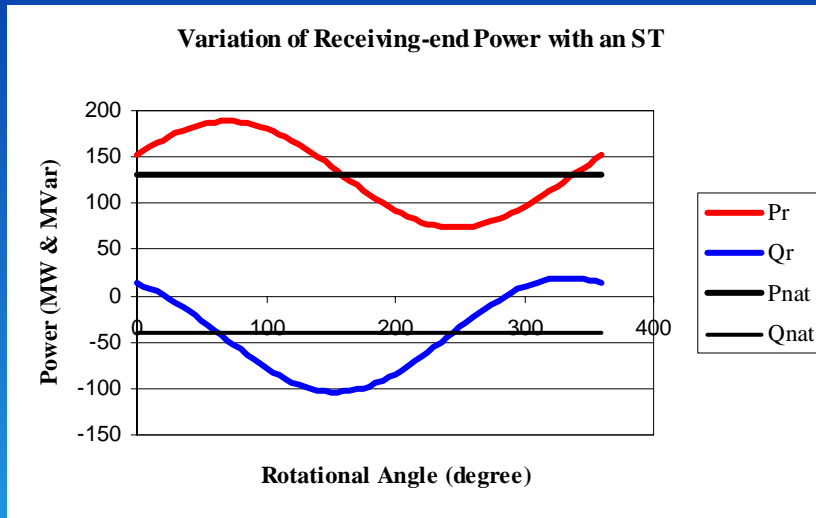

Simulation of ST and UPFC ($V_{s's} = 0.15$ pu)

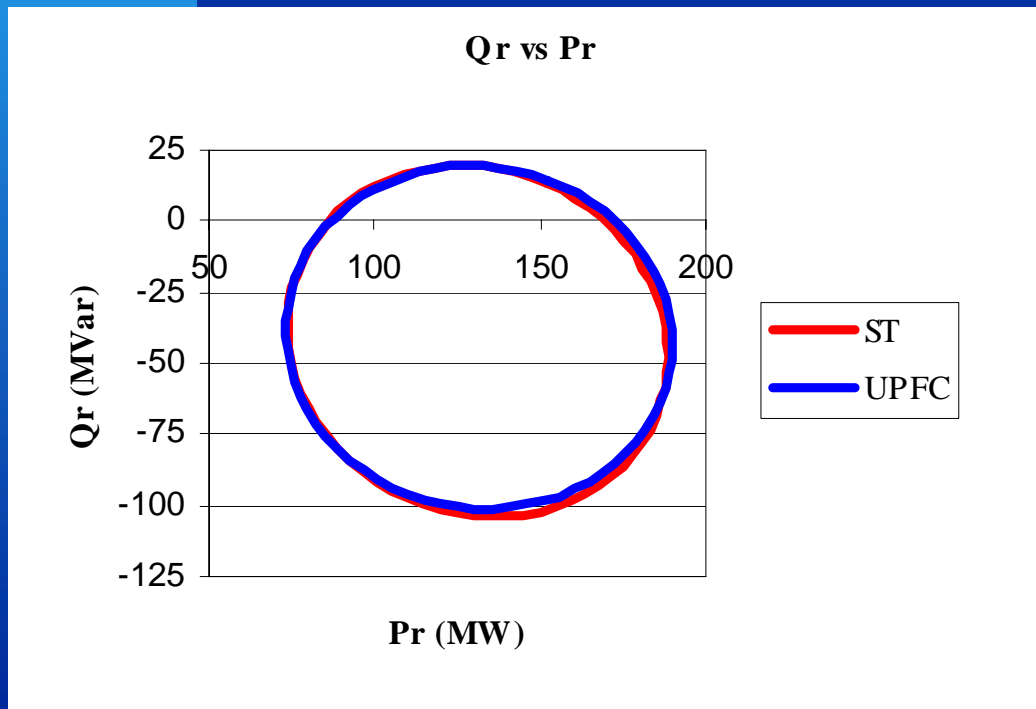

- Area of controllability in the P - Q plane for an ST and a UPFC are almost identical.

Aerial View of AEP UPFC at Inez Substation

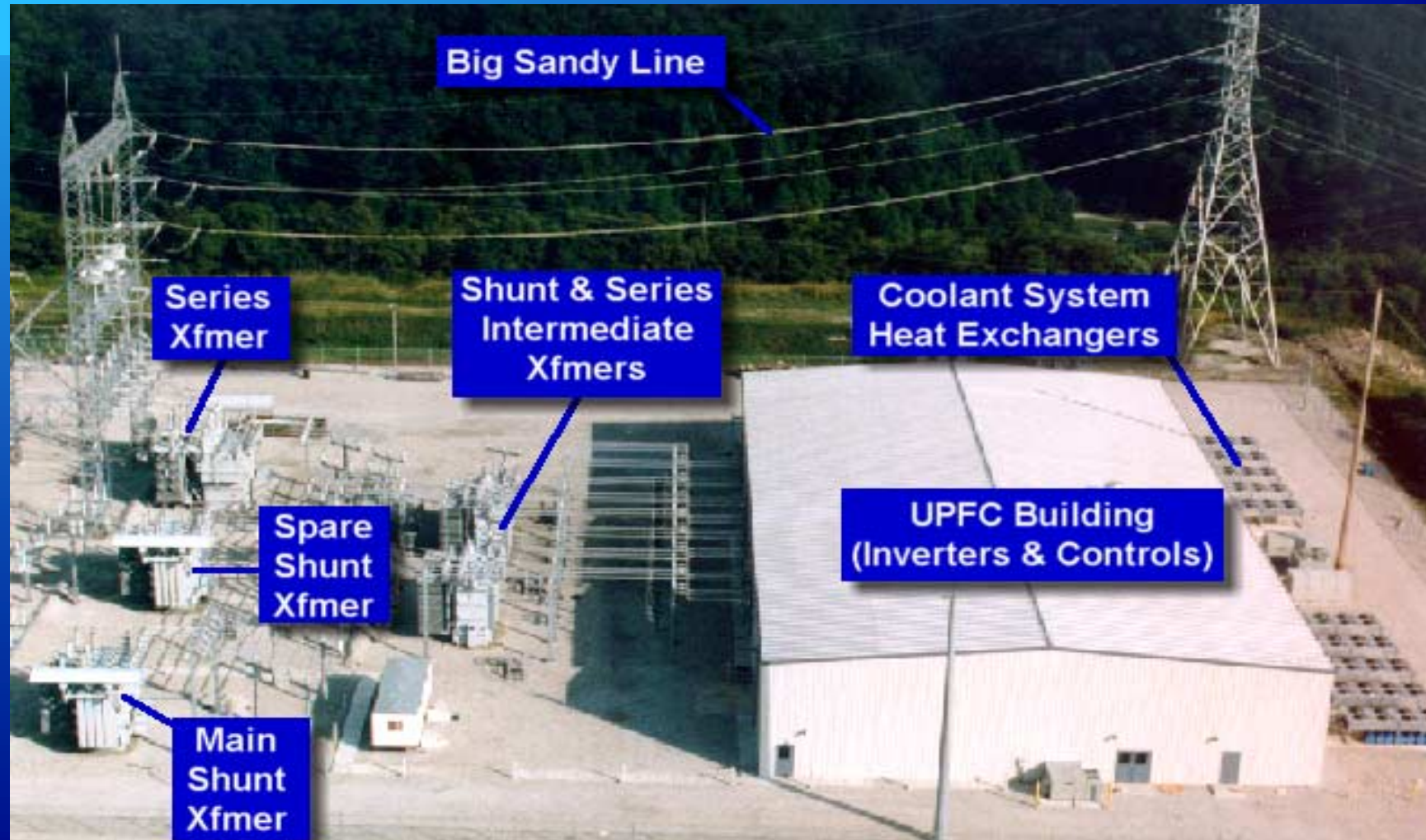

Advantages and Shortcoming of an ST

■ Advantages

- voltage regulation
- independent control of active and reactive power (P and Q) flow
- established transformer and load tap changer-based technology
- limited angle operation with reduced amount of hardware
- reliable and less expensive power flow controller
- low operating cost
- injection of line frequency voltage into the power system network
- high enough response for most utility applications

■ Shortcoming

- coarse voltage injection, which is acceptable for a utility application.

Main Differences Between Power Flow Controllers

	ST	PAR	VRT	UPFC
■ Voltage Regulation	X		X	X
■ Independent Line Active and Reactive Power Control	X			X
■ Low installation and operating costs	X	X	X	
■ Reliability and high availability	X	X	X	
■ Injection of line frequency voltage	X	X	X	
■ Low leakage reactance in the coupling Transformer	X	X	X	
■ Fast bypass switch not needed	X	X	X	
■ Fast response for utility applications	X	X	X	X
■ Coarse voltage injection	X	X	X	
■ Capability of independent reactive power generation and absorption				X

Main Differences Between Power Flow Controllers

- Losses
- Cost (\$/kVA)

ST	PAR	VRT	UPFC
<1%	<1%	<1%	3%-8%
15-20	15-20	10-15	75-100

Conclusion

- A new power flow controlling transformer is presented.
- 'Sen' Transformer
 - uses traditional technology of transformer and tap changers.
 - uses proven technology that is reliable.
 - provides four quadrant control of active power (P) and reactive power (Q) for an optimum system operation.
 - provides more features than a PAR at the same cost.
 - displaces UPFC for most utility applications.
- An emerging power flow controller market can be exploited with the right technology.